



# LED Deck Lights Instruction Manual

Cat No. LDK013K316, LDK01BU316, LDR01DECK

## 1 Specifications

Cat No	LDR01DECK	LDK013K316	LDK01BU316
Description	LED Deck Light Kit	White Deck Light	Blue Deck Light
Contents	1 x 15W LED Driver 10m Connecting Cable 4 x White Deck Lights	1 x White Deck Light	1 x Blue Deck Light
Supply Voltage / Input Power	230-240V a.c. 50Hz	24VDC 0.6W	24VDC 0.6W
Lumens Output	4 x 20lm	20lm	10lm
Light Colour	Warm White 3000K	Warm White 3000K	Blue
Average Beam Angle	65°	65°	65°
IP Rating	Driver IP68 2-pin Plug Not IP Rated	IP67	IP67
Deck Cutout Size	Ø28mm	Ø28mm	Ø28mm
Fascia Size	Ø35mm	Ø35mm	Ø35mm
Depth into Deck	43mm	43mm	43mm

## 2 Please read before commencing installation

- These deck lights are compatible with the 15W LED Driver (supplied with LDR01DECK) ONLY. Compatibility with other drivers cannot be guaranteed and may damage the deck light.
- The 15W LED Driver (supplied with LDR01DECK) can take a maximum of 25 deck lights (LDK013K316 or LDK01BU316).
- The 2 pin plug of LDR01DECK is not IP rated. It must be connected to a suitable IP rated socket.
- The LED Driver, cable connectors & deck lights are suitable for outdoor use. Refer to the Specifications section for their individual IP rating.
- These deck lights are not intended for underwater use such as in swimming pools, water fountains etc.

## 3 Installation

Before installation:

- Switch off the power source.
- Ensure that the cable lengths of the deck lights and driver are enough to suit the intended locations of the deck lights and power socket.

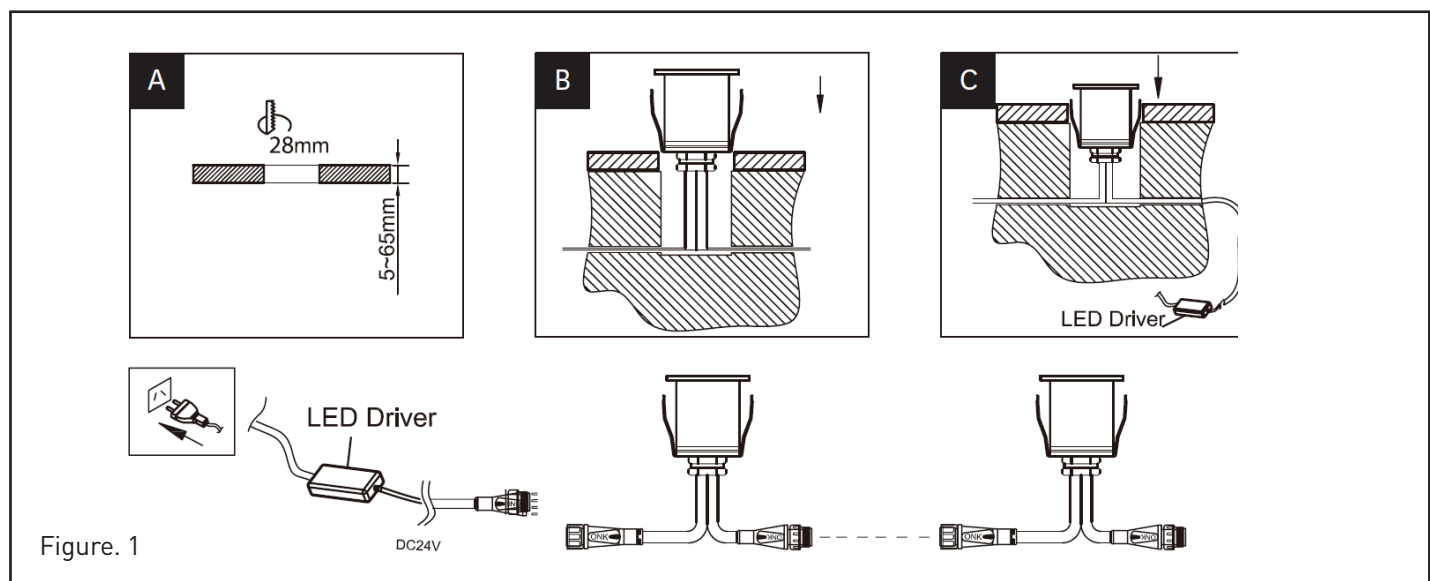
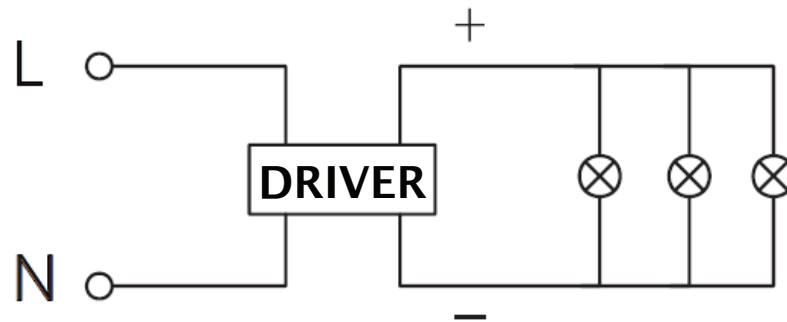

Figure. 2



**Note: Deck Lights to be wired in parallel.**

During installation, please do the following to ensure the IP rating of the deck light is maintained.

- Remove the end cap from the connector of the LED Driver. Attach the End Cap to the connector of the deck light that is at end of the daisy chain to prevent entry of water into connector.
- When connecting the male & female connectors, ensure the cover/cap is tightened securely.

## 4 Maintenance

This product should only be cleaned with a damp cloth. Cleaning agents and solvents should not be used.

## Disclaimers

1. This product must be installed and used as per these instructions.
2. An IP rating of IP67 means this product is completely protected against dust and against the effects of temporary immersion for depths between 15cm & 1m.
3. An IP rating of IP68 means this product is completely protected against dust and against the prolonged effects of immersion.
4. This product contains no serviceable parts and no attempt should be made to repair this product. If the product is faulty it should be discarded.
5. This product is not suitable for installation in hazardous and/or corrosive areas.
6. This product has been designed to operate in ambient temperatures -10°C to 45°C.
7. Electrical installations periodically receive transient over voltages. This product has been designed to minimise the effect of such voltages on connected equipment. It may not give full protection for extreme over-voltage transients such as those resulting from a close lighting strike.
8. This product utilises intellectual property in the form of registered designs, trademarks, and/or patents. Such intellectual property remains the property of HPM Legrand in all cases.
9. HPM Legrand reserves the right to modify the specification of this product at any time.

### Warranty

HPM Legrand warrants this product for a period of 6 years from the date of purchase.

These goods come with guarantees that cannot be excluded under the Australian and New Zealand Consumer Laws. You are entitled to a replacement or a refund for a major failure and for compensation for any other reasonably foreseeable loss or damage. You are also entitled to have the goods repaired if the goods fail to be of acceptable quality and the failure does not amount to a major failure.

See the Warranty card enclosed with this product for further details.

### Customer Service

For all Customer Service and Technical Support please call Monday to Friday during business hours.

Legrand Australia  
1300 369 777  
www.hpm.com.au

HPM Legrand New Zealand  
0800 476 009  
www.hpm.co.nz

ABN: 31 000 102 661

A Group brand | 