

OTHER COMPATIBLE LEGRAND SMOKE ALARMS

Legrand Reference	Mounting Type	Interconnect Type	Interconnect Compatibility with 643089
643088	Surface Mount	Wired & Wireless	Wired / Wireless
643090 / 643085	Surface Mount	Wired	Wired only
643091	Surface Mount	Wireless	Wireless only
643092 / 643087	Flush Mount (Ø 90 mm Cut-out)	Wired	Wired only

TABLE 1

INSTALLATION DESIGN

Legrand RF smoke alarm can be added to the existing wired Interconnect network. You must replace one of the existing wired smoke alarms with an RF unit that is also wired to do this.

- Understand your requirements and decide how and where you need the smoke alarm installed [See location section Fig. 6 for guidance]
- Determine which alarms are appropriate from our range [See Legrand smoke Alarms list Table 1]
- Run cabling if required.
- Mount base in the required position [See recommended location. Fig. 6].
Note: The RF units need to be paired before the base is mounted on ceiling.
- Commission and install [See commissioning and wiring sections for guidance]
- Test the installation.

REFER TO THE TABLE BELOW TO UNDERSTAND COMBINATIONS TO INTERCONNECT

Understand Installation Types		
Upgrade existing installation with wireless units	New installation with a mix of wired and wireless	New installation with only wired installation
<ul style="list-style-type: none"> You can have a mixture of wired and RF units on the one installation [See wiring section below] Existing installation with 2 or more wired interconnect units to extend the network with RF units. At least one existing unit must be replaced with a wired RF unit [Either 643088 or 643089] All new smoke alarms must be RF units [643088, 643089, 643091] 	<p>Install the RF versions where required [643088, 643089, 643091]</p>	<p>Install the wired interconnect versions where required [643090, 643092, 643085]</p>
Note: A maximum of 20 smoke alarms can be interconnected on one circuit.		

TABLE 2

STEPS TO INSTALL

Installation Type		
Upgrade existing installation with wireless units	New installation with a mix of wired and wireless	New installation with only wired installation
<ul style="list-style-type: none"> Pair all additional RF units to the network. After RF network setup is completed, clip units to mounted base and test. Remove existing smoke alarm and replace with a RF unit [either 643088 or 643089] If adding 240V RF versions - hard wire A & N to the new base. 	<ul style="list-style-type: none"> Gather all RF alarms to be installed and complete pairing to network. After RF network setup is completed, clip units to mounted base and test. On 240V RF units, hard wire A & N to new base. Connect interconnect wire to 'I' on the new bases. Note: RF only units [643091] need unit clipped into base to perform pairing. 	<ul style="list-style-type: none"> Hard wire 240V to A & N Connect interconnect wire to 'I' on the new bases. Clip units to mounted base and test
Note: A maximum of 20 smoke alarms can be interconnected on one circuit.		

TABLE 3

INTERNAL RF NETWORK SETUP

For easiest first-time setup, we recommend unpacking all units together on a desk, table or counter and using the steps in the following Table 4 below. If you prefer to install the alarms on the ceiling before connecting the units, attach all mounting brackets to the ceiling first and then start with step 2 in TABLE 4.

- Ensure all units are powered by clipping the base to head of the smoke alarm [battery activation]
- Pair all RF units on the bench.
- Validate RF network on the bench.
- Install base to ceiling if required and install smoke alarm.
- Validate installation.

Definition of key terminology

MASTER: This is the network master unit that is the key communicator with the other wireless units.
SLAVE: The other wireless units that are to be paired to the MASTER unit.

	User Input	Visual Indication	Time Limit
Step 1	Attach all units to mounting base, which will activate the battery [fig.4]	RED Light flashes once, then 3 fast flashes	N/A
Step 2	<ol style="list-style-type: none"> Choose one of the smoke alarm to be the MASTER. Hold down the Network button and count 6 to 8 flashes of the BLUE light then release. Place the MASTER unit away from the others as the MASTER will need to be identified later in the process. 	Solid BLUE light	Master mode will timeout in 9 min.
Step 3	SLAVE joining Network: Hold the Network button and count 3 to 4 flashes of the BLUE light then release to connect to other MASTER unit.	<p>Fast BLUE flashes indicates scanning for network.</p> <p>Slow BLUE flashes when connected to network.</p>	Timeout in 9 min. If timeout occurs go back to step 2 and either use the same MASTER unit previously selected or select any unit which is already part of the network to be the new MASTER unit.
Step 4	Exit Pairing Mode: Go to the MASTER smoke alarm (the one in step 2) and hold down the Network button and count 2 to 3 flashes of the BLUE light then release.	<p>Fast BLUE flashes on MASTER indicating network close.</p> <p>BLUE flashes on SLAVE will turn OFF.</p> <p>NOTE: Do not operate smoke alarm until the master stops flashing.</p>	Pairing Mode can take up to 90 seconds to close.

TABLE 4

- Clip the body of the smoke alarm to the base and turn ON 240V circuit, Green LED will be ON indicating AC powered.
- ADDING A SMOKE ALARM TO AN EXISTING RF NETWORK**
- At some point, you might want to add another smoke alarm unit to your existing RF network for additional protection or to replace an old unit. To do so follow the steps from Table 4.
- NOTE:** AFTER THIS SMOKE ALARM HAS REACHED THE END OF ITS LIFE, IT CAN BE RECYCLED AS E-WASTE.

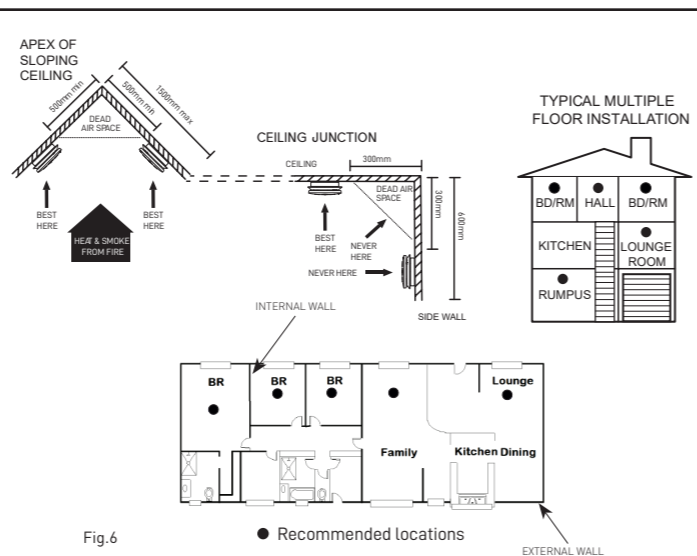

INSTALLATION LOCATIONS

- These recommendations are for information only. Check specific state legislation in your area to ensure smoke alarms are correctly located according to local laws. Each state or territory may differ in building codes and regulations.
- Install at least one alarm for each separate sleeping area. Try to cover the exit path as the bedrooms are usually farthest from an exit. If there is more than one sleeping area, install additional alarms in each sleeping area in the immediate vicinity of bedrooms.
- Locate additional alarms to monitor any stairway because stairways act like chimneys for smoke and heat.
- Locate at least one alarm on every floor level.
- Locate an alarm in every room where electrical appliances are operated (i.e portable heaters or humidifiers)
- Smoke, heat, and other combustion products rise to the ceiling and spread horizontally. Mounting the alarm on the ceiling in the centre of the room places it closest to all points in the room. Ceiling mounting is preferred in ordinary residential construction.
- When mounting alarms on the ceiling locate it at least 300 mm away from the sidewall and 300 mm away from any corner.

Terminals at back the of mounting base are marked as follows:

A - Active I - Interconnect N - Neutral E / Loop - Earth or Loop

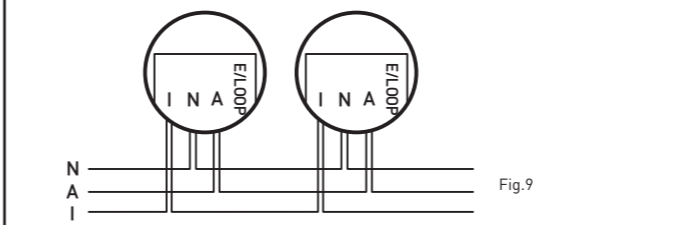
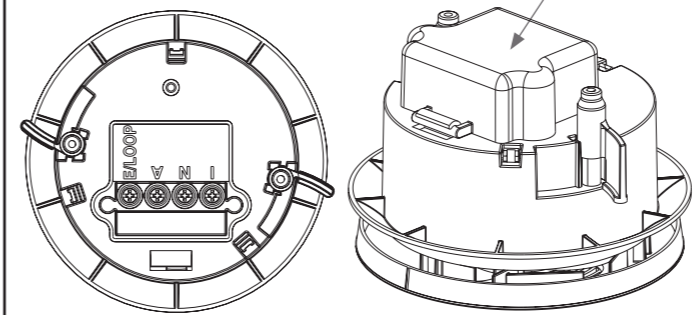
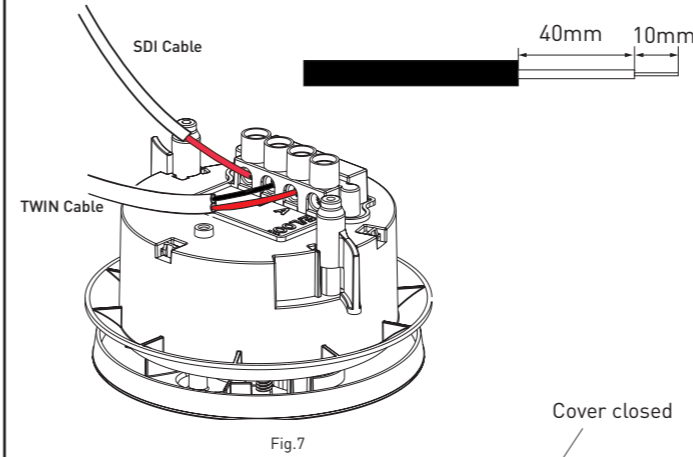

- There are four terminals in the supply terminal block marked A, I, N, and E/Loop. It is important that the alarm be wired correctly to ensure correct operation. Incorrect wiring to the smoke alarm will damage the unit and invalidate the warranty. See wiring diagram.
 - If connecting by RF mode the interconnect wire is not required.
 - If the unit is being installed in a new build, fully cover the unit with the plastic bag supplied to protect the unit from dust during the building construction stage. The plastic bag should only be removed at the end of the building construction phase, when the smoke alarm is to be commissioned. The building construction phase includes sanding, painting preparation, painting, flooring, etc. Once removed keep the plastic bag away from babies and children to avoid the danger of suffocation and must be disposed safely.
 - A maximum length of 300 meters of wire can be used to interconnect smoke alarms. Spacing between interconnected smoke alarms must not exceed 30 meters. Minimum wire cross-section of 1.00mm² to be used.
 - Wired interconnected smoke alarm must be connected to the same final sub-circuit. This is not required if connecting via RF.
 - Do not use any wire that could later be confused with the normal house wires for the interconnect wire. For example Green/ Yellow, Earth wire.
 - Do not connect AC power wired to the terminal marked 'I' (Interconnect). This will damage the smoke alarm.
 - Interconnect feature is only compatible with other Legrand smoke alarms. Refer to Table 1. This unit will be damaged if interconnected with another brand of smoke alarm.
 - Smoke alarm should be interconnected only within the confines of a single-family living unit. If smoke alarms are interconnected between different units, there may be excessive nuisance alarms and residents may not be aware that smoke alarms are being tested or that it is a nuisance alarm caused by cooking, etc.
- Note:** The smoke alarm should be installed on a separate circuit to minimize false triggering.

WARNING

- Connecting the interconnect terminal to any supply conductor will result in danger to the alarm and fail to operate and /or introduce a shock hazard and will void the warranty of the alarm.
- Under no circumstances must an insulation resistance test be carried out on a circuit to which a smoke alarm is connected. The test could cause irreparable damage to the internal circuitry of the smoke alarm and make it inoperative. The warranty would be void under such circumstances.
- If no alarm sounds, check wiring, fuses, or circuit breaker and make sure that the alarm is connected to a continuous final sub-circuit.

OPERATING MODES

- The smoke alarm is operational once:
- All wires are properly connected.
 - The smoke alarm is correctly installed on the mounting base.
 - The alarm has been tested.

Legrand RF smoke alarms are capable of linking together to make a unique network. When one RF or hard-wired Interconnected unit senses smoke, it sounds an alarm and triggers all other units on the same network to sound an alarm. Only the originating smoke alarm will have a flashing RED LED.

VISUAL AND AUDIBLE INDICATIONS

GREEN	VISUAL INDICATION		SOUND PATTERN	MEANING
	RED	BLUE		
Solid ON	N/A	N/A	N/A	Unit is connected to 240V a.c.
OFF	N/A	N/A	N/A	Unit is not connected to 240V a.c
N/A	N/A	N/A	3 beeps in 4 sec (1 cycle)	Wired unit being tested
N/A	N/A	1 Flash in 4 sec	3 beeps in 4 sec (1 cycle)	RF unit being tested
N/A	N/A	N/A	3 beeps in 2 sec (1 cycle)	Other wired units on the network being tested
N/A	N/A	1 Flash in 4 sec	3 beeps in 2 sec (1 cycle)	Other RF units on the network being tested.
N/A	N/A	Solid ON	N/A	This is the Master smoke alarm
N/A	N/A	2 Flashes every sec	N/A	Slave is searching for Network
N/A	N/A	1 Flash every sec	N/A	Slave connected to Network
N/A	N/A	Fast flashing for 90 sec	N/A	Master smoke alarm exiting pairing mode
N/A	N/A	Single flash, followed by 3 flashes	N/A	Smoke alarm is battery activated
N/A	N/A	1 Flash every 300 sec	N/A	Normal operation (Standby mode)
N/A	N/A	1 Flash every minute	Single beep every minute	Low battery indication [End of life]
N/A	N/A	3 flashes every 4 sec (1 cycle) and repeats	3 beeps every 4 sec (1 cycle) and repeats	Smoke detected (Wired Unit)
N/A	N/A	3 flashes every 4 sec (1 cycle) and repeats	Flashes once every 4 sec	Smoke detected (Wireless Unit)
N/A	N/A	Flashes once every 4 sec	3 beeps every 2 sec (1 cycle) and repeats	Smoke alarm interconnect (Triggered by wireless unit)
N/A	N/A	N/A	3 beeps every 2 sec (1 cycle) and repeats	Smoke alarm interconnect (Triggered by wired unit)

TABLE 5

TESTING (NETWORK TEST ONLY)

This test is performed to check if:

- All the smoke alarm units on one network are all interconnected and working as it should be.
- To check if all smoke alarm units on a network are within the working range.
- Before testing, make sure that the smoke alarm is connected to the AC power supply and the Green LED is ON.

	User Input	Detector Response	Timeout
Step 1	Select one of the RF Smoke Alarm in the network: Hold the network button for 10-12 seconds.	Solid BLUE light	Master mode will timeout in 9 min
Step 2	After 30 seconds visually check all other RF units.	Slow BLUE flashes	Timeout in 9 min.
Step 3	Exit Network Test Mode: Go to the MASTER smoke alarm (the one in step 1) and hold down the Network button and count 2 to 3 flashes of the BLUE light then release.	<p>BLUE light on the MASTER will flash fast followed by the BLUE lights on all SLAVES turning OFF.</p> <p>This may take up to 90 seconds.</p>	Network is closed

TABLE 6