



# Datasheet Super LED Satellite

CAT. NO. 659021LI, 659022LI



Cat. No.	659021LI	659022LI
Colour	Grey	Black
Operating Mode	Non-maintained	
Nominal Input Voltage	230 - 240 V a.c. 50Hz	
Battery	Li-ion 12.8 V 1.5 Ah	
Inrush Current	5 A	
Power Consumption	5.2 W	
Light Source Life (LSL)	100,000 hrs	
Operating Temperature	10° C to 40° C	
Lighting Classification	C <sub>0</sub> /C <sub>90</sub> D100	
Body Construction	Polycarbonate	
IP Rating	IP65	
IK Rating	IK07	
Compliance	AS/NZS2293, AS/NZS60590, AS CISPR 15	
Product Marking	  <b>R-NZ</b>	



# Super LED Satellite

CAT. NO. 659021LI, 659022LI



## FEATURES

- Embedded Bluetooth for smart device connectivity.
- Low Power Wide Area Network type of communications utilising the LoRa platform.
- LoRa communication to maximise reliability, coverage and infiltration.
- Suitable for high ceilings and large areas.
- iSmart™ temperature sensing technology for Li-ion battery.
- Electronics designed to lengthen the life of the battery.
- Several mounting options: surface, wall bracket, suspension rod or suspension wire.
- Available in grey and black finish.
- One high brightness LED.
- D100 Emergency classification.
- 5 Year Warranty.
- Design and Manufactured in Australia.

Cat. No.	Description
659021LI	Super LED Satellite, D100 ,IP65, Surface Mounting - Grey
659022LI	Super LED Satellite, D100, IP65, Surface Mounting - Black

Accessories	
686266	Suspension Rod Kit, 1200mm length - Grey
686267	Suspension Rod Kit ,3000mm length - Grey
686268	Suspension Rod Kit, 1200mm length - Black
686269	Suspension Rod Kit, 3000mm length - Black
685034	Suspension Wire Kit - Grey
685035	Suspension Wire Kit - Black
685036	Wall Bracket - Grey
685037	Wall Bracket - Black

## SPACING TABLE

Maximum spacing between luminaries for 0.2lux (Australia)

Mounting Height	9m	10m	15m
D100	34.5m	35.2m	36.5m

As per AS/NZS 2293:2018

Maximum spacing between luminaries for 1lux (New Zealand)

Mounting Height	9m	10m	15m
D100	15.4m	14.4m	-

As per AS/NZS 2293:2018

## DIMENSIONS

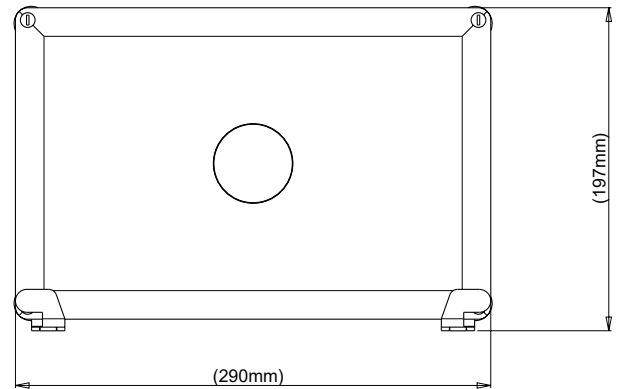
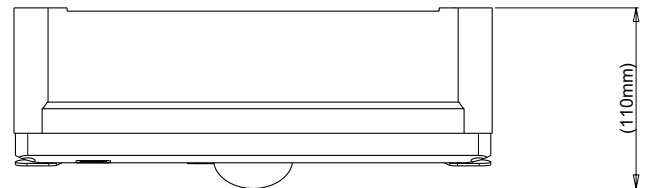

Legrand - Australia  
1300 369 777  
www.legrand.com.au  
ABN 31 000 102 661

Legrand - New Zealand  
0800 476 009  
www.legrand.co.nz

Refer to your group buying office, Legrand Sales Representative or Legrand Sales Office for pricing.

Please note: specifications are subject to change without prior notice.



LEG2505C

03/2022