

Features

- These screws are fitted on request to meet public works department specifications.
- When fitted with screws the mechanism can withstand 0.7j impact from the front (IK05).
- Screws must be hand tightened to 0.6Nm max.
- Use Truss head screws for 1-3 gang grid and use washer head screw for 4 gang grid.

Installation

1-3 Gang switch grid

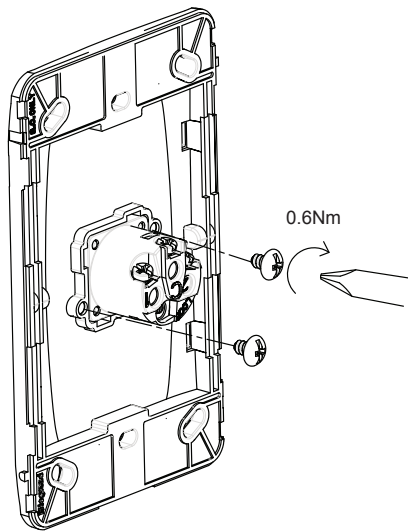

4 Gang switch grid

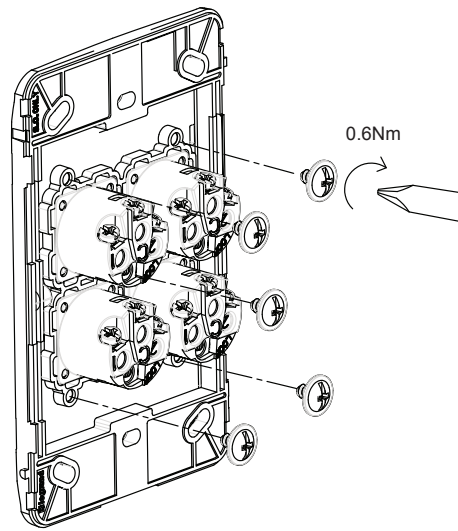

Warranty

Legrand Cat EAPWDSCREW series is warranted as here and after appears, against faulty material and/or workmanship for a period of one year from the day of purchase. The obligation of the manufacturer under this warranty is limited to servicing and replacing defective parts when the unit is returned to the authorised place of purchase, at the purchaser's cost. To obtain warranty repair, the purchase receipt should be returned with the product. This warranty becomes void on any unit which has been tampered with or damaged by accident, short circuited, loaded beyond rating or damaged otherwise by improper operation. The warranty is also conditional on the unit being installed by a licensed electrical contractor. Our goods come with guarantees that cannot be excluded under the Australian Consumer Law. You are entitled to a replacement or refund for a major failure and compensation for any other loss or damage. You are also entitled to have the goods repaired or replaced if the goods fail to be of acceptable quality and the failure does not amount to a major failure.

Customer Service

For all Customer Service and Technical Support please call Monday to Friday during business hours.

HPM Legrand Australia
1300 369 777
www.hpmlegrand.com.au

HPM Legrand New Zealand
0800 476 009
www.hpmlegrand.co.nz

ABN: 31 000 102 661