

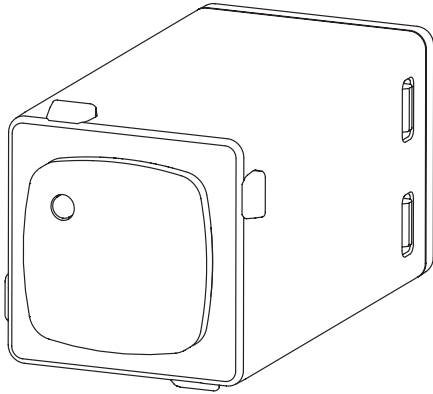

Push Button Dimmer 2-Wire LED Compatible

Cat. 400A2PM

Instruction Sheet



Wiring

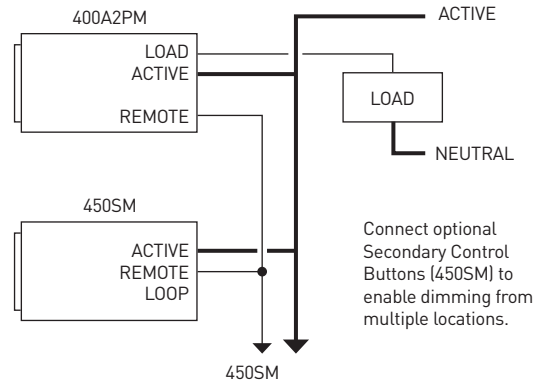

Note: An unlimited number of 450SM can be connected to an 400A2PM. However, the total length of the remote wire used to interconnect all of the 450SM should not exceed 50 metres.

Technical characteristics

+50°C +0°C 230-240V a.c. 50Hz	 1 x 2.5mm ² 2 x 1.5mm ²	■ Incandescent ■ Halogen	■ Halogen or dimmable LED with electronic transformer ■ Dimmable compact fluorescent ■ Dimmable LED without transformer	■ Halogen with wirewound transformer	Fluorescent tube	Fan motor	
		Max Power	Max number of transformers ¹				
Max load	1 dimmer per plate	350W	350VA	8	X	X	X
	2 dimmers per plate	300W	300VA	8	X	X	X
	3 or more dimmers per plate	250W	250VA	8	X	X	X

Note:

1. In the case of dimmable compact fluorescent or dimmable LED without transformer, this is the maximum number of lamps.
2. Where both max power and max number of transformers/lamps are specified, both conditions must be satisfied.
3. When used in ambient temperatures greater than 25°C, the dimmer must be de-rated by 10% for every increase of 5°C.

Operation

- A short button press turns the dimmer on and off. When turned on, the dimmer will ramp up to the same brightness level as when it was last turned off.
- A long button press will cause the dimmer brightness to go up or down. When dimming up, dimming will stop when maximum brightness is reached, and when dimming down, dimming will stop when minimum brightness is reached. Release the button and then hold down again to change the dimming direction.
- Over-temperature protection: If the dimmer gets too hot (due to overloading or insufficient de-rating), the lamp brightness is automatically reduced. After the dimmer cools down, normal operation is automatically resumed.
- Short-circuit protection: If the dimmer receives a short circuit or surge (due to faulty wiring or lamp failure), it automatically turns itself off before damage can occur. Simply press the push-button to resume operation.

Important

The default maximum brightness of the dimmer has been factory set to suit HPM LDL Series LED lamps. However, it is possible that the factory setting may need to be increased for other LED lamp models. To do this, please see "Advanced Programming Mode" over the page.

WARNING - DO NOT MEGGER THIS PRODUCT

LED indicator

- The colour of the LED indicator can be either blue or red. In addition, when the dimmer is off, the LED indicator can either glow faintly or be off completely. The four possible modes are as follows:

Mode	Status	
	Dimmer On	Dimmer Off
1 (factory default)	Bright blue	Faint blue
2	Bright red	Faint red
3	Bright blue	Off
4	Bright red	Off

- To change between modes, press and hold the push button for at least 10 seconds. When the LED colour changes to violet, release the button.
- LED indicator will not illuminate when lighting load is disconnected.

Advanced programming mode

Advanced Programming can only be performed within 15 minutes after power is applied to the dimmer, to ensure that the settings cannot be changed inadvertently. To allow subsequent access to Advanced Programming, the dimmer must be powered off at the supply and back on again. All settings are stored in non-volatile memory and will be retained in the event of a power failure.

To enter Advanced Programming mode:

1. Press and hold the push button. After 10 seconds the LED colour changes to violet.
2. Keep holding the push button for a further 10 seconds.
3. When the LED starts flashing once every 2 seconds, release the push button.

Once in Advanced Programming Mode:

- A short button press will move to the next feature.
- A long button press will adjust the feature.
- No activity for 15 seconds will save all settings and exit Advanced Programming Mode.

To restore factory defaults:

- Turn off power to the dimmer at the supply.
- While holding down the push button, turn on power to dimmer at the supply.
- Keep the button held down for 10 seconds.
- The LED indicator will flash red, blue and violet to indicate that factory defaults have been restored.

Advanced programming features

The following table explains how to program each advanced feature:

Advanced Feature	LED Indicator	Lamp Load	Long Button Press	Short Button Press
1 – Set Minimum Brightness	Flashes red once every 2 seconds	On at minimum brightness setting	Set the new minimum brightness	Move to next advanced feature
2 – Set Maximum Brightness	Flashes red 2 times every 2 seconds	On at maximum brightness setting	Set the new maximum brightness	

Important information

- This product must be installed and used as per these instructions.
- This product must be installed by a licensed electrician or similarly qualified person.
- V90-rated building wire must be used when wiring this product.
- This product is a solid state device, so there is still mains voltage present at the load even when the dimmer is switched off. HPM Legrand recommends that power be switched off at the circuit breaker before replacing faulty lamps.
- This product must only be used with the loads specified. Other load types should only be used when written confirmation is given by HPM Legrand.
- This product has been designed to filter out interference from off-peak electricity signalling. The level of such signalling will vary from installation to installation and interference is still possible in rare cases.
- This product has been designed with limited short circuit protection. Repeated short circuits may still damage the product.
- Severe electromagnetic interference from other products may cause malfunction of this product.
- This product should only be cleaned with a damp cloth. Cleaning agents and solvents should not be used.
- This product contains no serviceable parts and no attempt should be made to repair this product. If the product is faulty it should be discarded.
- HPM Legrand reserves the right to modify the specifications of this product at any time.

Warranty

HPM Legrand will honour all statutory guarantees that you as a consumer are entitled to rely upon under the Australian and New Zealand Consumer Law against a manufacturer including a guarantee that any products HPM Legrand has manufactured or imported are of acceptable quality.

To make a claim under any statutory guarantee (or other warranty) you should first contact the supplier, contractor or retailer from whom you purchased the products.

Customer Service

For all Customer Service and Technical Support please call Monday to Friday during business hours.

HPM Legrand Australia
1300 369 777
www.hpm.com.au

HPM Legrand New Zealand
0800 476 009
www.hpm.co.nz

ABN: 31 000 102 661

A Group brand 