

⚠ Safety notes

This product should be installed in line with installation rules, preferably by a qualified electrician. Incorrect installation and use can lead to risk of electric shock or fire. Before carrying out the installation read the instructions and take account of the product's specific mounting location. Do not open up, dismantle, alter or modify the device except where specifically required to do so by the instructions. All Legrand products must be opened and repaired exclusively by personnel trained and approved by Legrand. Any unauthorised opening or repair completely cancels all liabilities and the rights to replacement and guarantees. Use only Legrand brand accessories.

The device contains a LiMnO₂ primary cell. When the product reaches the end of its life, this cell must be correctly removed and disposed of in accordance with national legislation and the requirements of environmental protection.

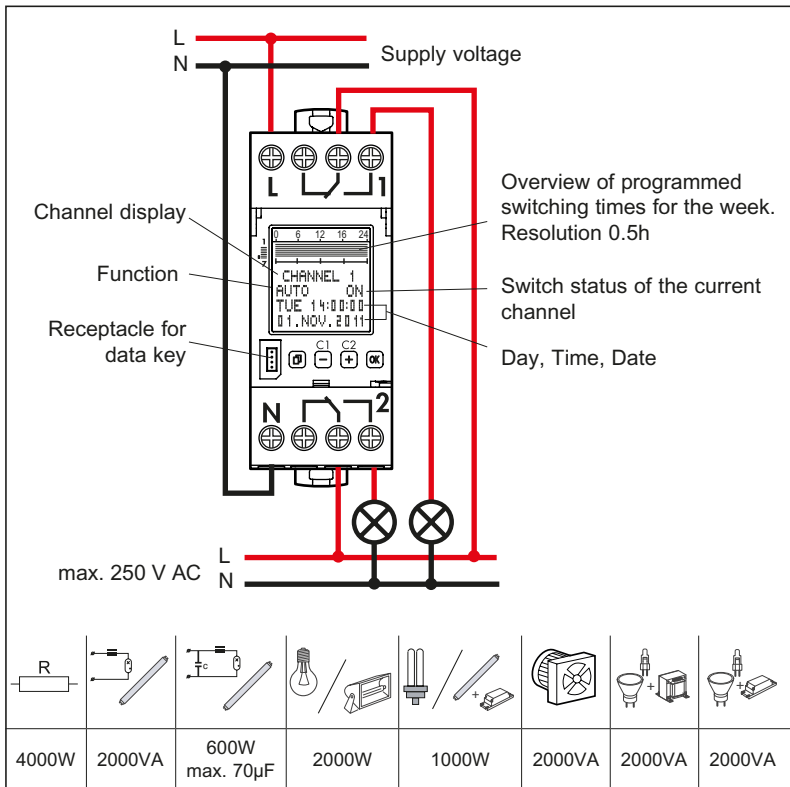

Operating principle: Typ 1.B. S. T.
IEC/EN 60730-1, IEC/EN 60730-2-7
Operation in a normal environment
Montage: in distribution panel, Degree of contamination: 2
Switch output, potential-free
Rated impulse voltage: 4 kV

General information

- Start-up: after applying the supply voltage, the time switch starts automatically with the last selected function. The relay position is set by the current program.
- Battery backup
 - Backlighting not active
 - Data key READ/WRITE only via the menu
- For safety, when the time switch is connected to the mains supply the contact should not be used on an isolated low voltage supply and when the time switch is connected to the isolated voltage supply the contact should not be used on the mains supply.

- Select menu, back to main menu, Hold down > 1s = operating display
- Confirm selection or load parameters
- Select menu options or set parameters
- Channel selection

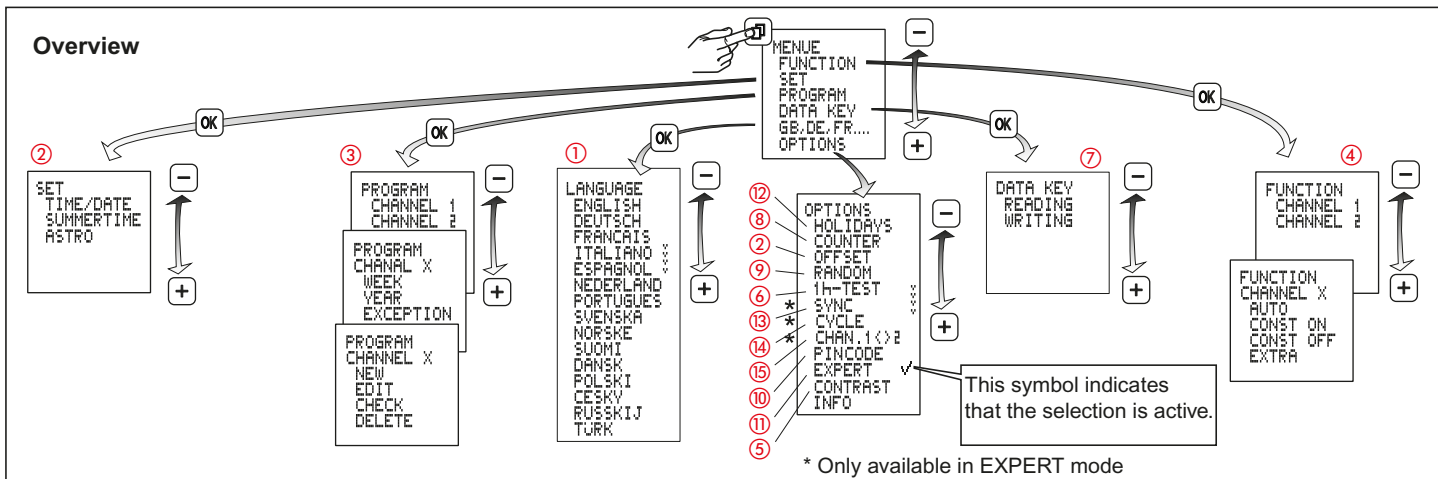

Technical data	4 126 57	4 126 58	4 126 59	Local coordinates:	Resolution 1°/ 1' in EXPERT-Mode
	047 67	047 68	047 69		
Supply voltage:	230V 50/60Hz	120V 50/60Hz	24V 50/60Hz	Battery reserve:	5 years
Power consumption:	1,5 W			Storage temperature:	- 20°C to +60°C
Relay outputs:	2 changeover contact 16A 250V~µ cos φ = 1			Operating temperature:	-20°C to +55°C
Accuracy:	~ 0,1 s/day				
	single-strand	multi-strand			
Wire cross-sections:	1,5...4 mm ²	1,5...2,5 mm ²			
Programs	2 channels x 28 programs				

1 Set language

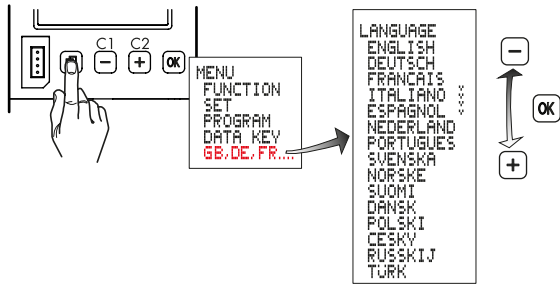

2 Set

A Set time/date

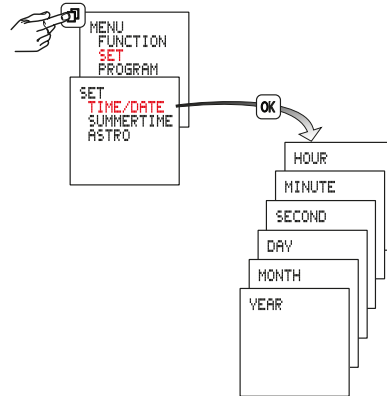

B Summertime

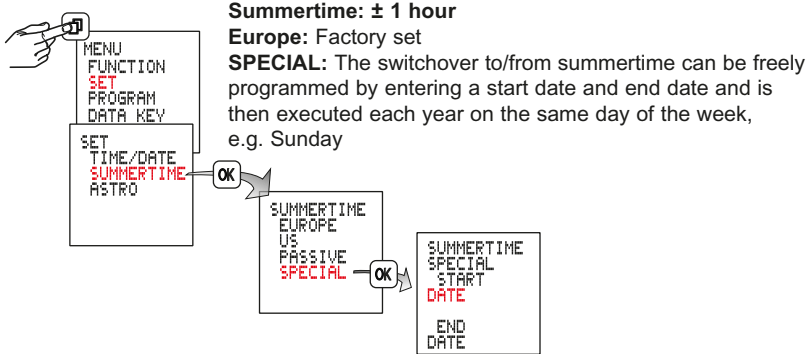

C Astro

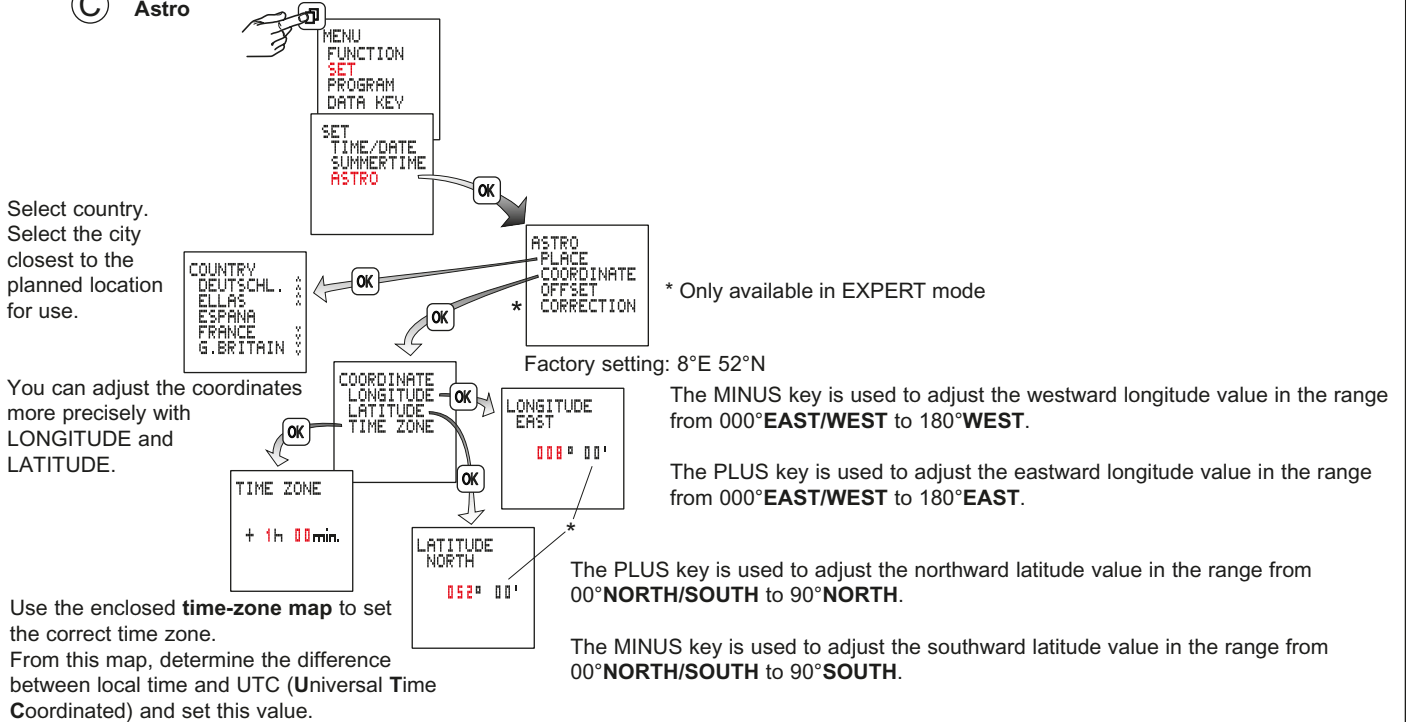

D Offset

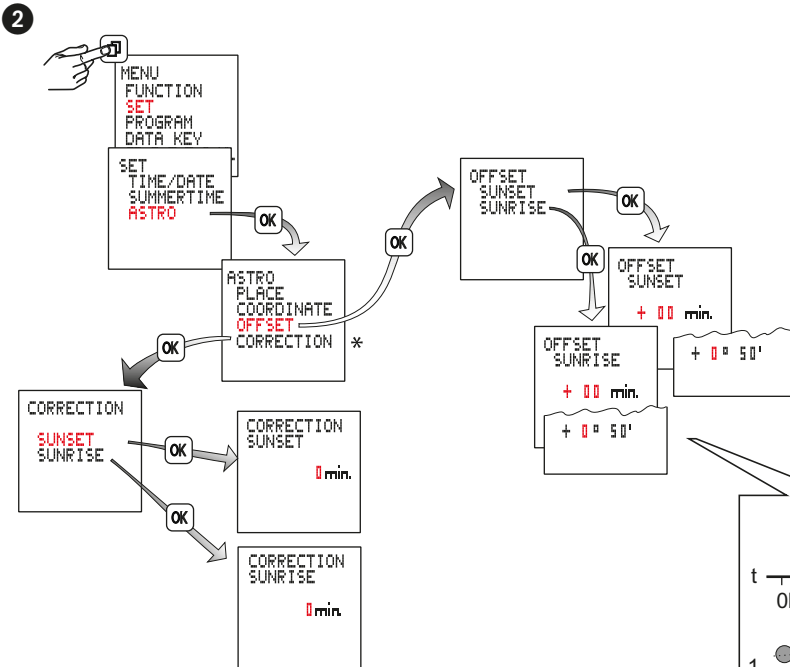
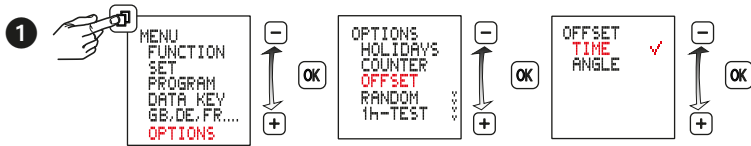

* This function is available in Expert mode.

Setting the correction value (1...30 min.) extends the daily ON period in the middle of the winter season by up to 60 minutes (OFF up to 30 min. later in the morning, ON up to 30 min. earlier in the evening).

In the middle of the summer season, the correction setting reduces the daily ON period by up to 60 minutes (OFF up to 30 min. earlier in the morning, ON up to 30 min. later in the evening).

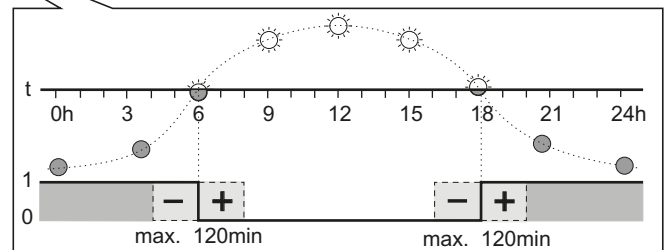
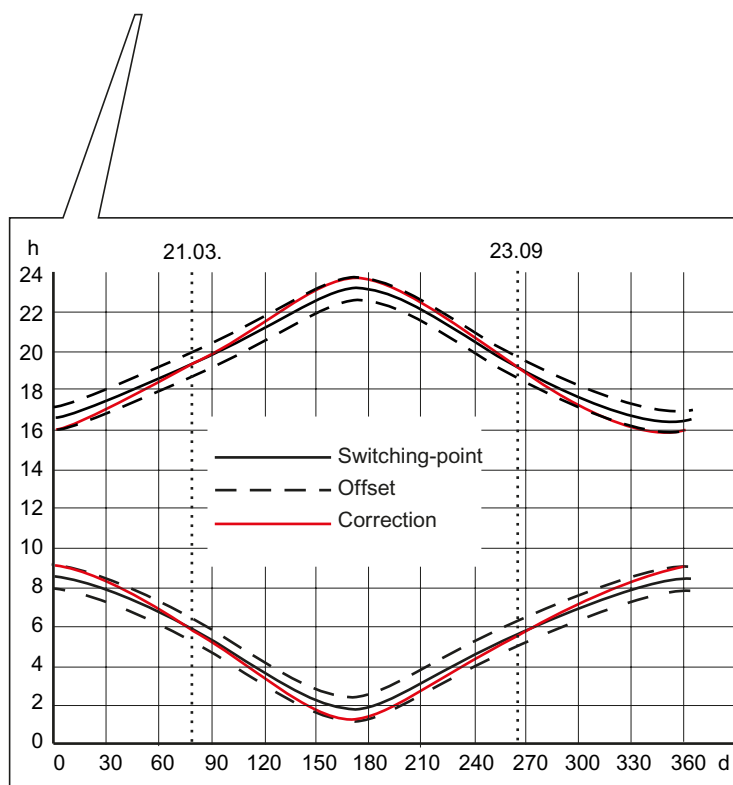

The time switch switches on at the calculated sunset time and off at the calculated sunrise time.

By setting an offset, you can shift the switching times by up to ± 120 minutes with respect to the calculated sunrise and sunset times.

Example: If you set the offset to +30 minutes, the time switch will switch 30 minutes after sunrise and 30 minutes after sunset. If you set the offset to -30 minutes, the time switch will switch 30 minutes before sunrise and 30 minutes before sunset.

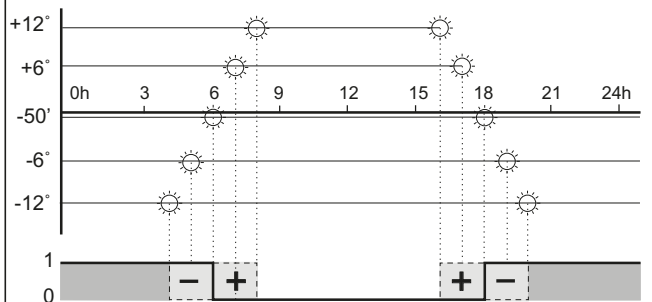

If the offset setting is in degrees the time switch switches on and off at times of equal brightness, despite the differences in twilight time lengths over the course of the year.

Sunrise and sunset correspond to -50' for the centre of the sun (the edge of the sun is visible on the horizon).

3

Programming

A program consists of an ON time, an OFF time and the associated ON and OFF days.
 If you select „MON TO SUN“ (Monday to Sunday), the days are already assigned and you only need to set the ON and OFF times.
 If you select „INDIVIDUAL“, you can assign the ON and OFF times to any desired days.
 The programs are linked to one another by logical OR.

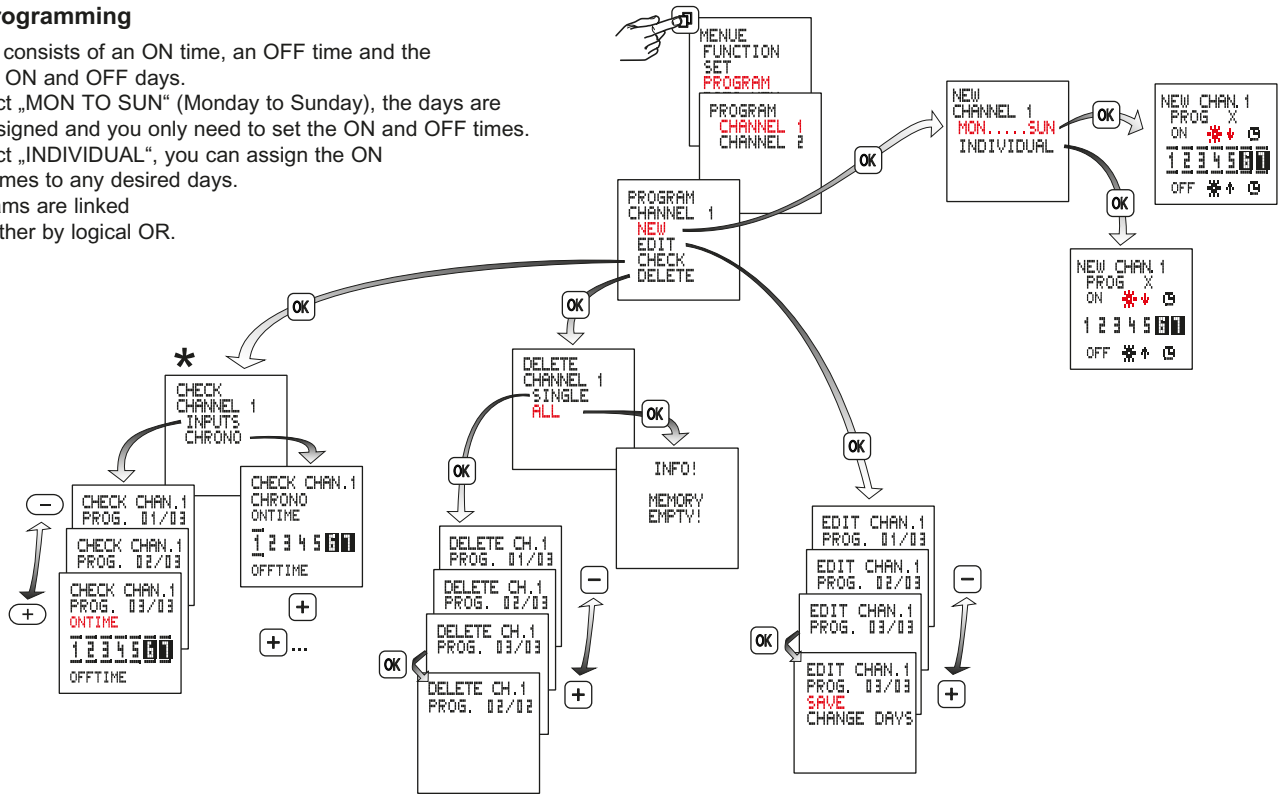

*
 CHRONO = the switching times are indicated in chronological order during the week.
 INPUT = programs are indicated in the order in which they are entered.

Programming examples

① The timer is to switch on at sunset on each day of the week and switch off at sunrise.



Select the appropriate symbol with the PLUS and MINUS keys:

- ☀️ ↓ ON at sunset
- ☀️ ↑ OFF at sunrise
- 🕒 ON/OFF at programmed time

② The timer is to switch on at sunset on each day of the week and switch off at sunrise. In addition, it is to be switched off each night between 23:00h and 5:00h. This requires the use of two programs.

Program 1: ON at sunset and OFF at 23:00h
 Program 2: ON at 5:00h and OFF at sunrise.

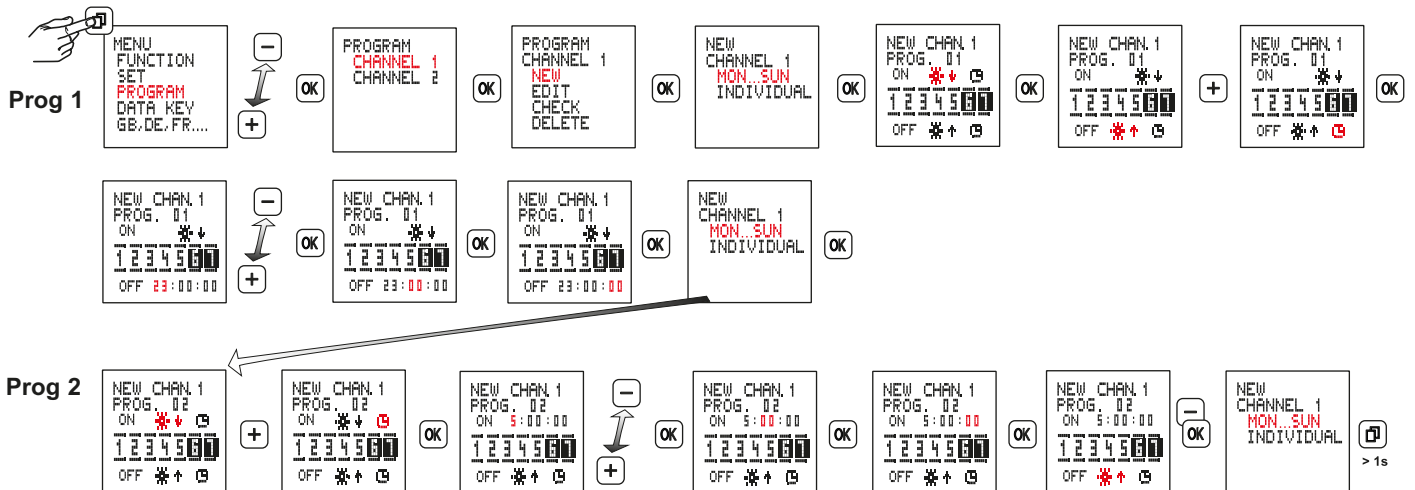

4 Modes

- **Auto** - Automatic operation
- **Constant ON**
- **Constant OFF**
- **Extra**

The switch status imposed by the program is inverted (manual override). With the next effective switch command, the time switch resumes control of ON/OFF switching.

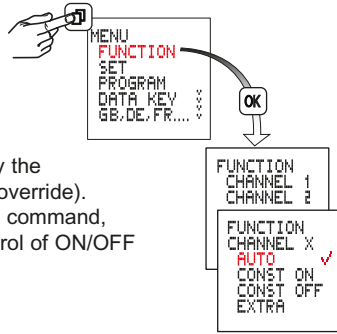

Reset

Warning!

The memory will be cleared, and all set data will be lost.

Hold down **OK** for more than 3 seconds and at the same time press and release **OK** **-** **+**.

The language, time, date, summertime/wintertime and switching times will have to be reentered.

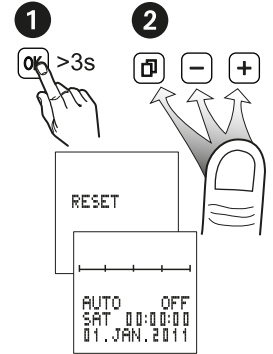

5 Contrast adjustment

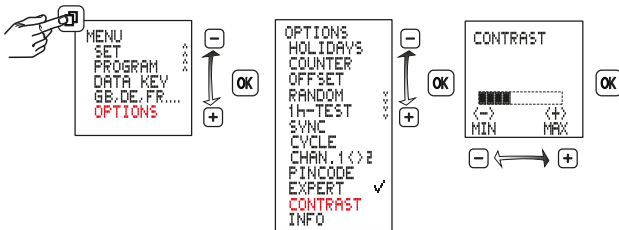

6 1 h-Test

When this function is activated, the output is switched ON for one hour.

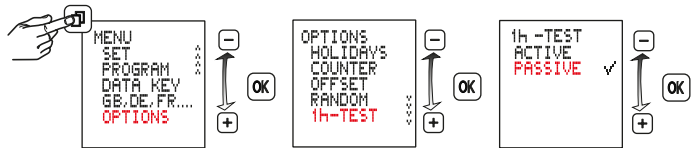

After one hour, the time switch returns automatically to the programmed mode.

7 Data key

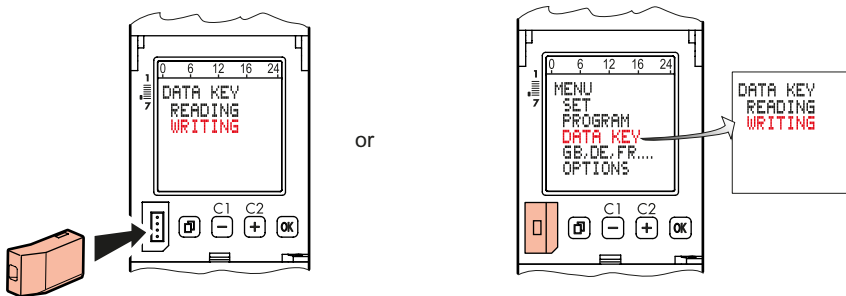

Load the programs of the time switch on to a data key (WRITE KEY)

Warning! all programs stored on the data key will be overwritten.

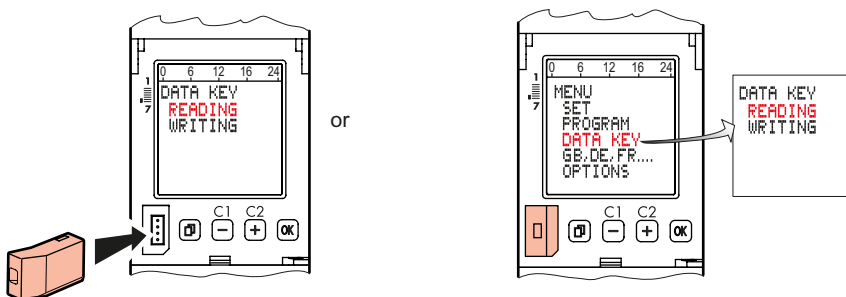

Load the programs from the data key to the time switch (READ KEY)

Warning! all programs stored in the time switch will be overwritten.

8 Hour counter

Displays the total relay ON time (0 to 65535 h) and the date of the last reset.

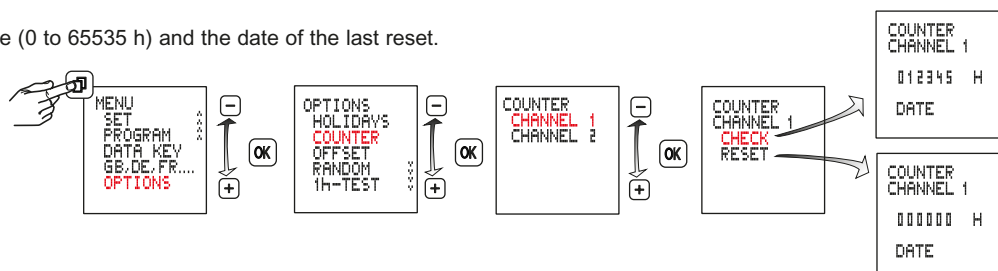

9 Random function

Function to simulate presence.

Function active: the programmed switching cycles are shifted at random within the range of ± 15 minutes.

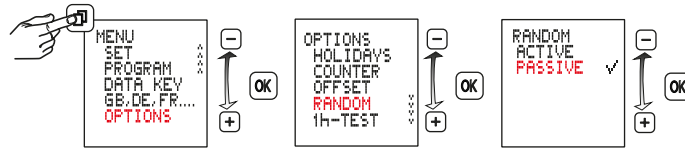

10 Pincode

PIN CODE active: The menus of the time switch will not be accessible unless the PIN CODE has been entered. When the pin code is active, access to the button and key functions is disabled 1 minute after the last button press.

PIN free access can be re-enabled by selecting PASSIVE or by resetting the device.

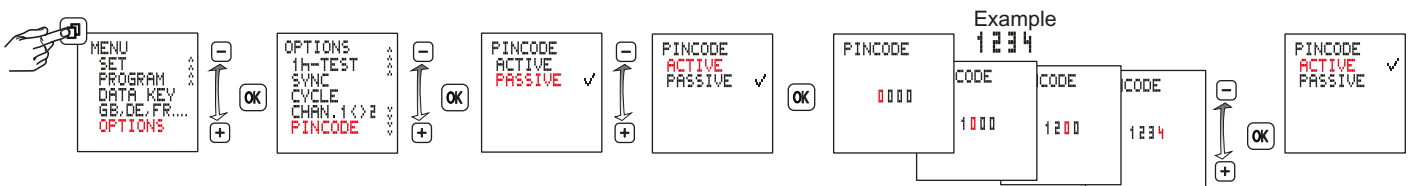

11 Expert mode

Some additional functions are available in Expert mode:

- Power grid synchronisation to improve the accuracy
- Cycle function
- Summer / winter seasonal correction
- Automatic channel switching

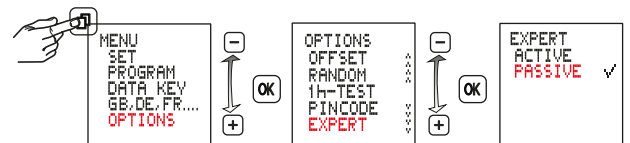

Note: Upon switching from ACTIVE to PASSIVE the additional menu items are hidden again and all the Expert mode settings are cancelled. After re-activating, Expert mode will operate again with the basic settings.

12 Holidays

After activation the holiday program is executed between 0:00h on the start date and 24:00h on the end date (Constant ON/OFF).

After the holiday program has run once, it must be reactivated.

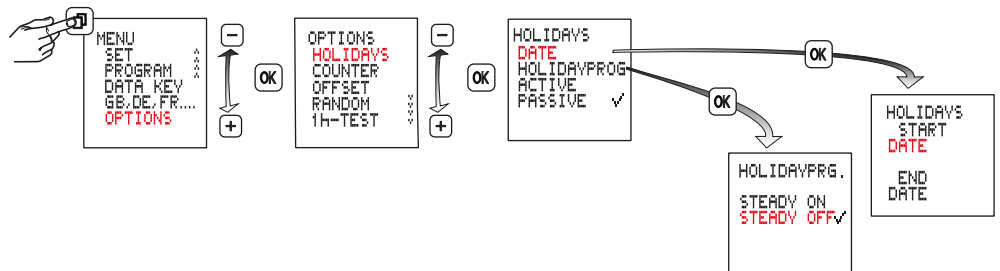

13 Activating and deactivating grid synchronisation

Only available in EXPERT mode.

The default setting is PASSIVE. In order to improve the long-term accuracy, it is advisable to activate synchronisation if the time switch is supplied from a on 50/60 Hz grid with frequency adjustment.



14 Cycle function

Only available in EXPERT mode

For cyclical switch commands the switching on time is set by logical "OR" of programs of all types. A fixed cycle of ON and OFF time then operates within those limits. The cycle always starts with the ON time.

The cycle duration and the ON time within the cycle have the same length for all switching times. The cycle duration and the ON time can be set independently in one-second increments. If the switching time is shorter than the cycle duration, the cycle will be shortened accordingly. The ON time will remain unchanged. If the switching time is actually shorter than the ON time, the ON time will be shortened accordingly.

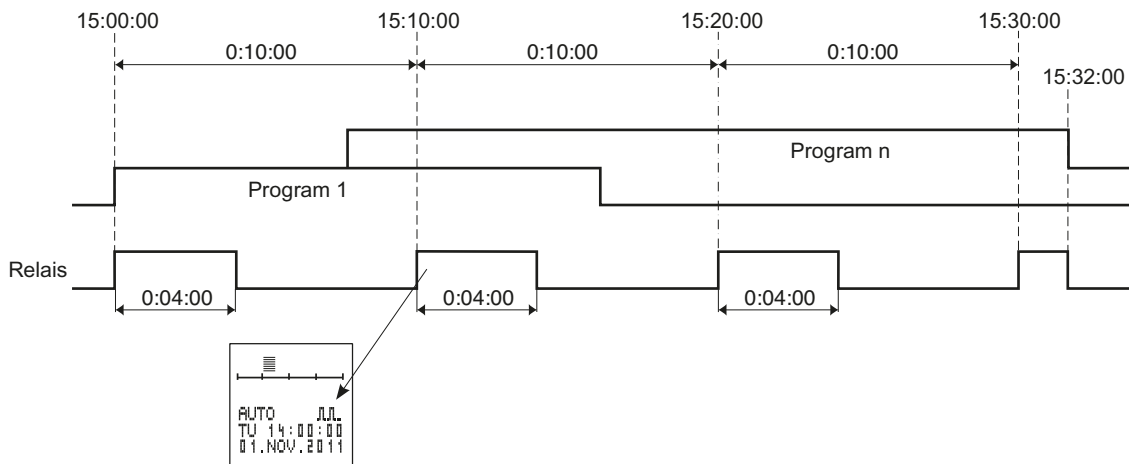
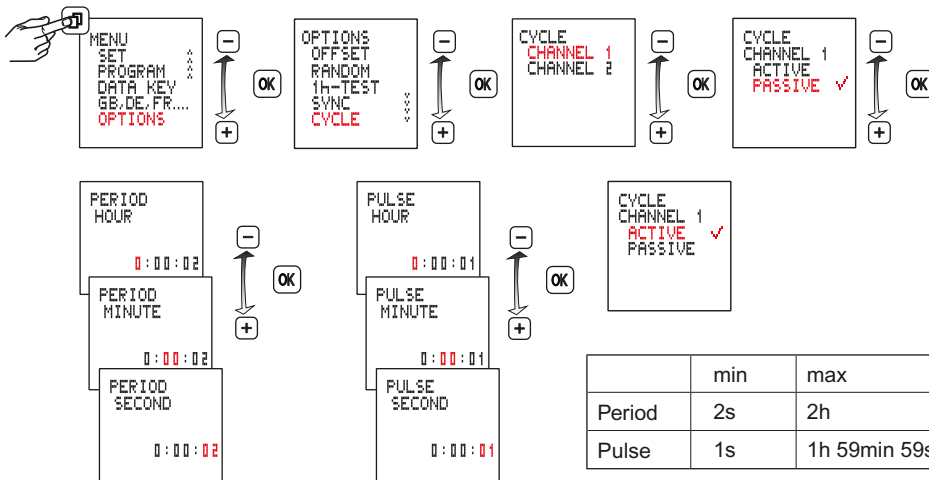

15 Automatic channel switching

Only available in EXPERT mode

On two-channel time switches a cyclic switch between channels can be set to conserve and/or ensure even use of connected equipment such as lamps and lights.

For example, with two sets of lights, one can be used all night long and the other for part of the night only. However, cyclical inversion of the outputs ensures that the lamps are on for the same length of time on average.

The outputs are automatically swapped over once a day (12 noon) or once a week (Sunday at 12 noon).

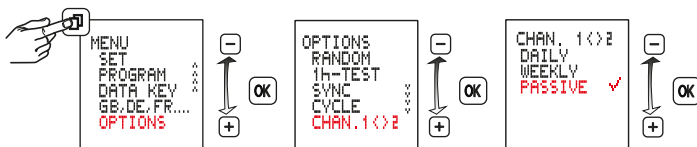

Warning: Electrical shock - Disconnect all power from the device before dismantling the module and replacing the battery.

Always use a Li cell type battery (LiMnO₂) CR2477, 3V high temperature type min +85 °C

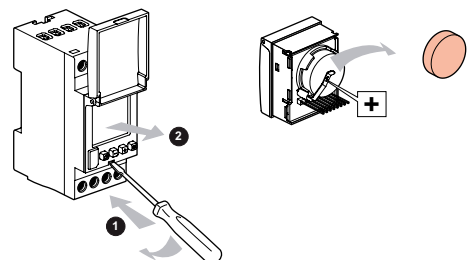

- Zeitzonekaart
- Carte des fuseaux horaires
- Time-of-day map
- Tijdszone kaart
- Carta dei fusi allegata
- Carta de husos horarios
- Time-of-day oversigt
- Aikavyöhykekarttaa
- Tidssonenkortet
- Tidzons kartan
- Carta de fusos horarios
- ηώρα ώραΌμια ατῶνἙσμ
- Ajavõändite kaart
- Laika zonu karte
- Laiko juostų žemėlapis
- Mapa stref czasowych
- Mapas ss časovými pásmami
- Karta časovnih pasov
- Mapa časových pásem
- Időzóna térkép
- Zaman dilimleri kartı
- 时区图
- خريطة مناطق التوقيت

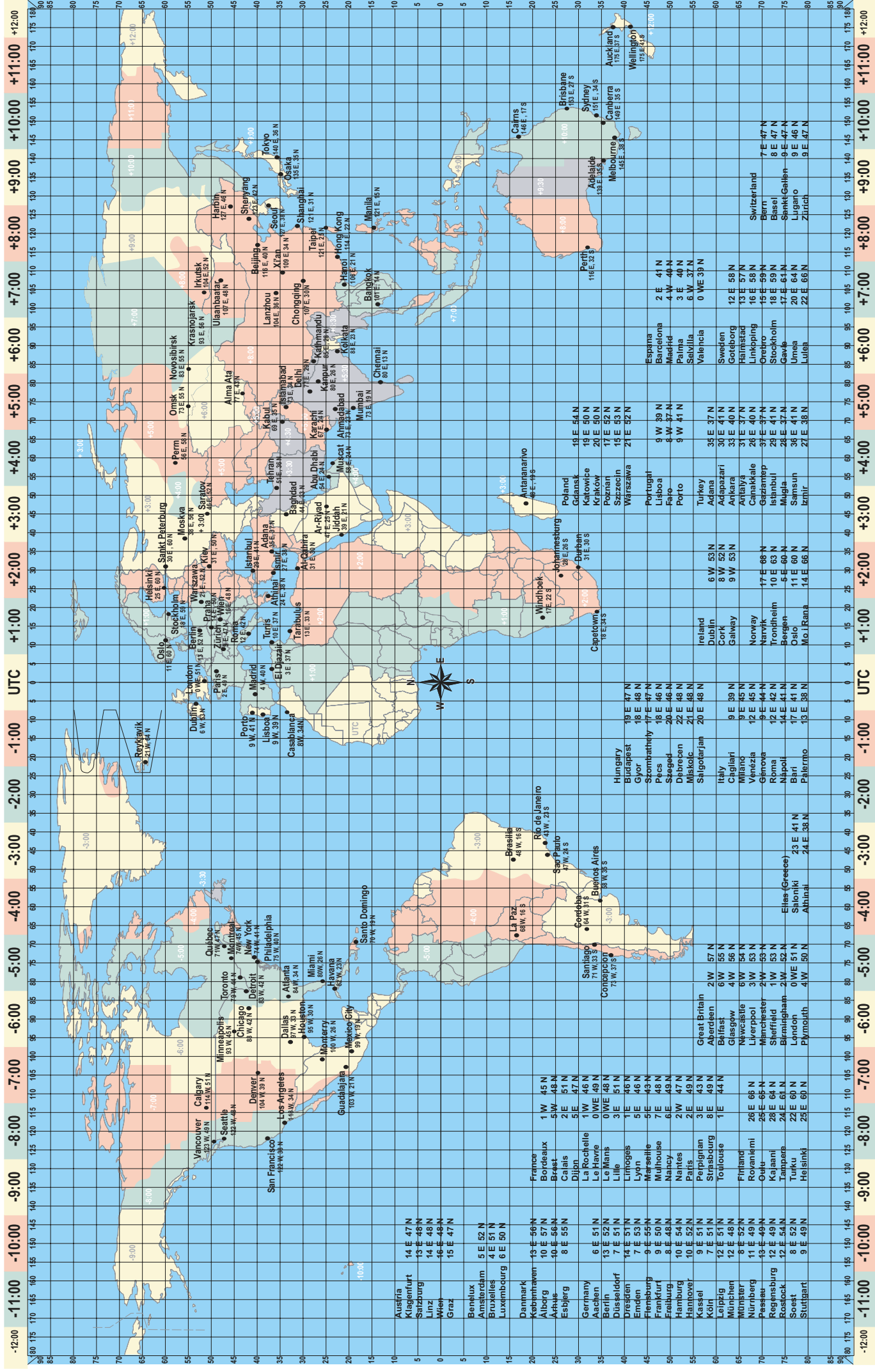

-12:00	-11:00	-10:00	-9:00	-8:00	-7:00	-6:00	-5:00	-4:00	-3:00	-2:00	-1:00	UTC	+1:00	+2:00	+3:00	+4:00	+5:00	+6:00	+7:00	+8:00	+9:00	+10:00	+11:00	+12:00
--------	--------	--------	-------	-------	-------	-------	-------	-------	-------	-------	-------	-----	-------	-------	-------	-------	-------	-------	-------	-------	-------	--------	--------	--------