

0 670 94

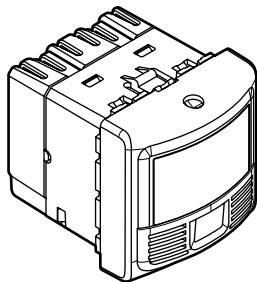

0 784 52
0 792 52

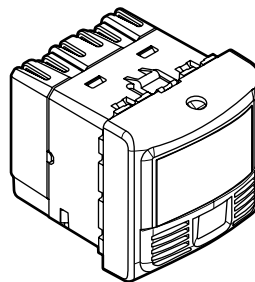

5 740 49
5 740 99

CONTENTS

Page

1. Use	1
2. Technical characteristics	1
3. Dimensions	2
4. Connection	2
5. Installation	3
6. Operation	3
7. Settings	4
8. Performance	5
9. Care	6
10. Standards and approvals	6
11. Troubleshooting	6

1. USE

This device allows a light source to be controlled automatically through the detection of any presence in the surveillance zone using local controls.

Presence sensor with 180° detection angle.
Detection type: infrared (PIR) and ultrasound (US)
Assembly type: wall flush mounted

2. TECHNICAL FEATURES

Voltage: 100 - 240 V~
Frequency: 50/60 Hz
No-load power consumption: 0.4 W
Output via normally open contact connected to the phase
Wiring: 2 x 2.5 mm²
Flush-mounting box: 40 mm min.
Weight: 60 g
Impact resistance: IK04
Penetration by solid and liquid matter: IP20
Usage temperature: - 5°C to + 45°C
Storage temperature: - 20°C to + 70°C
Number of terminals: 4
Type of terminals: screw
Terminal capacity: 2 x 2.5 mm²
Stripping length: 8 mm

2. TECHNICAL CHARACTERISTICS (continued)

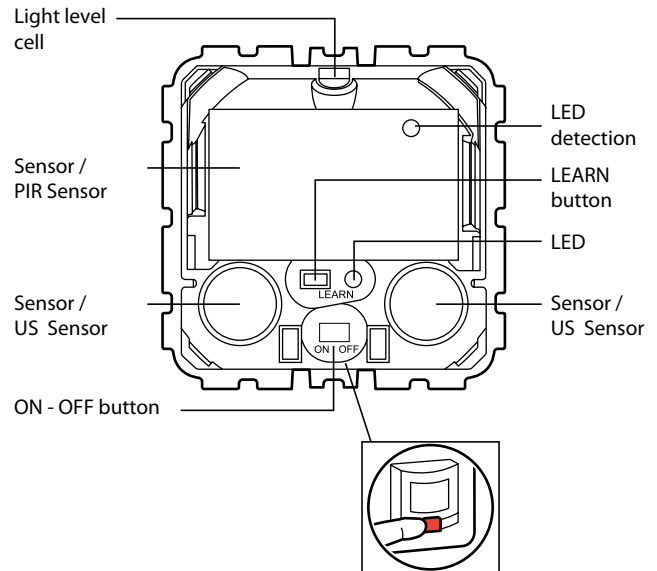

①	②	③	④	⑤	⑥	⑦	⑧	⑨	⑩				
230 V~	2000 W	8.5 A	1000 VA	4.3 A	10x(2x36 W)	4.3 A	500 VA	2.1 A	1000 VA	4.3 A	500 VA	2.1 A	I max. ≤ 2A
110 V~	1000 W		500 VA		5x(2x36 W)		250 VA		500 VA		250 VA		

- 1 - Halogen bulb
- 2 - ELV halogen bulb with separate electronic ballast
- 3 - ELV halogen bulb with separate ferromagnetic ballast
- 4 - Fluorescent tube with separate ferromagnetic ballast
- 5 - ELV fluorescent tube with separate electronic ballast
- 6 - Compact fluorescent bulb with built-in electronic ballast
- 7 - Compact fluorescent bulb with separate ferromagnetic ballast
- 8 - Compact fluorescent bulb with separate electronic ballast
- 9 - LED bulb
- 10 - Contactor

3. DIMENSIONS

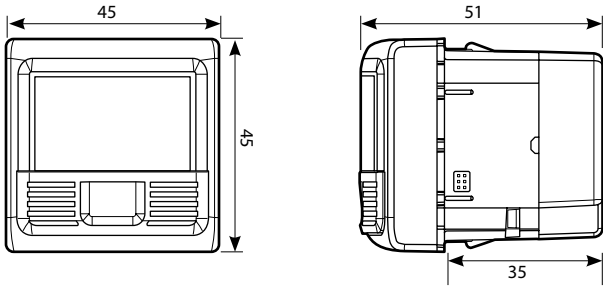

4. CONNECTION

■ **4.1 Wiring with auxiliary control:**

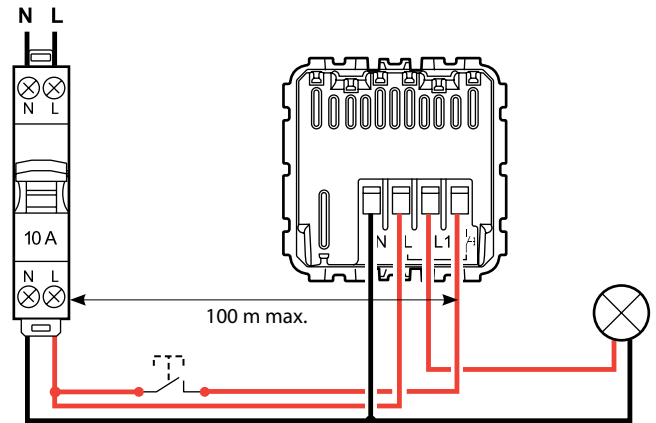

4. CONNECTION (continued)

■ **4.2 Wiring for several loads connected in parallel**

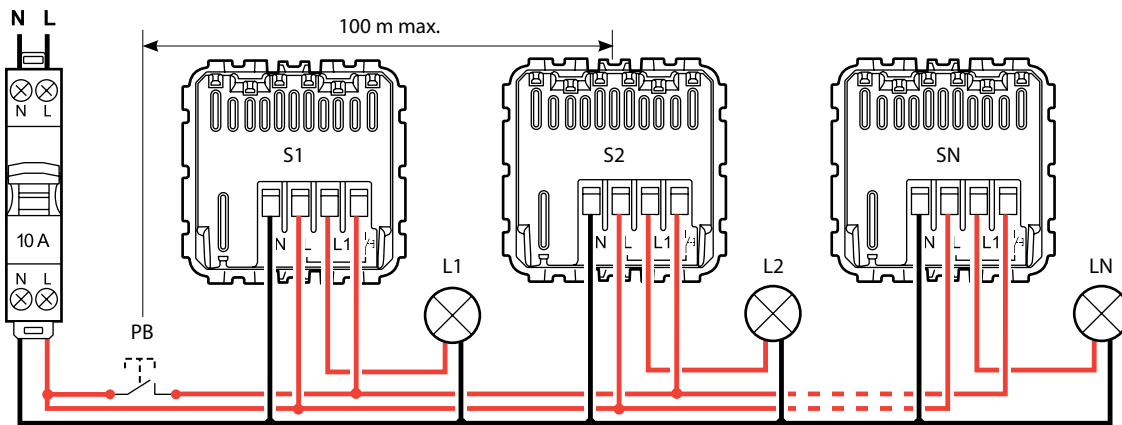

■ **4.3 Wiring for a single load connected in parallel**

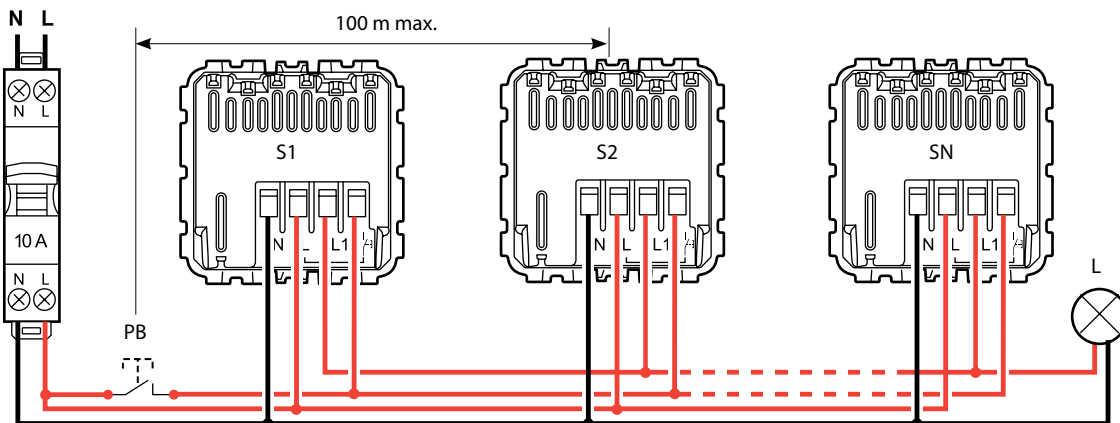

5. INSTALLATION

5.1 Sensor positioning

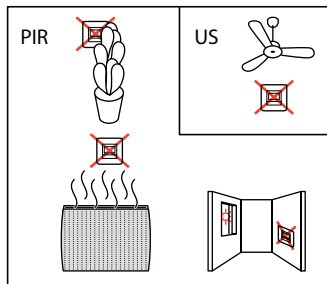
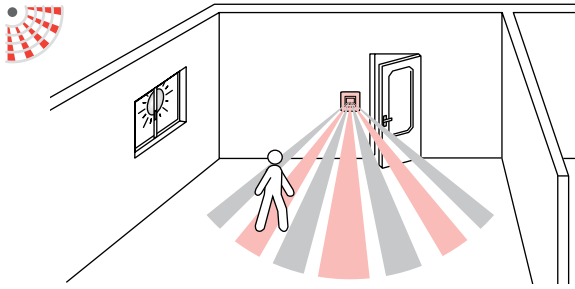

5.2 Recommended light exposure

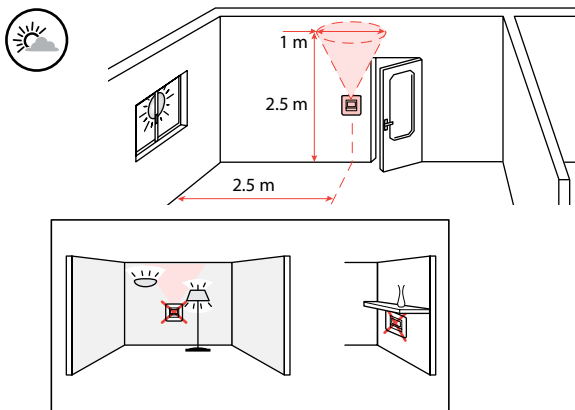

5.3 Positioning

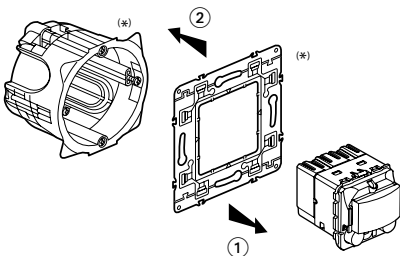

(*) Not supplied

6. OPERATION

6.1 More than one sensor and more than one load

Manual ON/Automatic OFF mode

Pressing the auxiliary control allows the load to be switched on or off manually. If the control is not pressed, the sensor will cut off the load at the end of the time delay or when the light level threshold has been reached.

Auto ON/OFF mode:

The load will be switched on and off automatically.

Option: It is possible to control the sensor by infrared remote control using: Cat. Nos. 0 882 00/01/20/31/32/33.













































Synchronising the products is done in two stages:

- one long press (>1s) all the sensors (S) switch to the ON state
- one short press all the sensors (S) switch to the OFF state

⊗ L1 OFF ⊗ L2 OFF ⊗ Ln OFF	☐ S1 OFF ☐ S2 OFF ☐ Sn OFF	PB < 1 s	☀ L1 ON ☀ L2 ON ☀ Ln ON	☐ S1 ON ☐ S2 ON ☐ Sn ON
☀ L1 ON ☀ L2 ON ☀ Ln ON	☐ S1 ON ☐ S2 ON ☐ Sn ON	PB < 1 s	⊗ L1 OFF ⊗ L2 OFF ⊗ Ln OFF	☐ S1 OFF ☐ S2 OFF ☐ Sn OFF
☀ L1 ON ⊗ L2 OFF ⊗ Ln OFF	☐ S1 ON ☐ S2 OFF ☐ Sn OFF	PB < 1 s	⊗ L1 OFF ☀ L2 ON ☀ Ln ON	☐ S1 OFF ☐ S2 ON ☐ Sn ON
☀ L1 ON ⊗ L2 OFF ⊗ Ln OFF	☐ S1 ON ☐ S2 OFF ☐ Sn OFF	PB > 1 s + < 1 s	⊗ L1 OFF ⊗ L2 OFF ⊗ Ln OFF	☐ S1 OFF ☐ S2 OFF ☐ Sn OFF
☀ L1 ON ⊗ L2 OFF ⊗ Ln OFF	☐ S1 ON ☐ S2 OFF ☐ Sn OFF	PB > 1 s	☀ L1 ON ☀ L2 ON ☀ Ln ON	☐ S1 ON ☐ S2 ON ☐ Sn ON

6. OPERATION (continued)

6.2 Several sensors connected to a single load

 L OFF	  	 < 1 s	 L ON	  
 L ON	  	 < 1 s	 L OFF	  
 L ON	  	 < 1 s	 L ON	  
 L ON	  	 < 1 s + > 1 s	 L OFF	  
 L ON	  	 > 1 s	 L ON	  

7. SETTINGS

7.1 Detection parameters

Sensor parameters		Default value	Modifiable parameters	Configuration tools	
				0 882 30	0 882 35
Time delay		15 mins	3, 5, 10, 15, 20 min 0 - 59 min 59 s	-	✓
Sensitivity		PIR (very high)/US (high)	Low, medium, high, very high	✓	✓
Modes	Auto on/Auto off	Inactive	Activate/Deactivate	✓	✓
	Walk-through mode	Inactive	Activate/Deactivate	✓	✓
	Manual on/Auto off	Active	Activate/Deactivate	✓	✓
Detection system	Initial	PIR and US	PIR and/or US, PIR, US	✓	-
	Maintain	PIR or US	PIR and/or US, PIR, US	✓	-
	Restart	PIR or US	PIR and/or US, PIR, US, Deactivate	✓	-
Alarm		Inactive	Activate/Deactivate	✓	-

 **Time delay:** Length of time the load is on after detection.

 **Sensitivity:** Detection range setting.

Modes:

 **Auto on/Auto off mode:**

Comes on automatically:

- At the detection of a presence if there is an insufficient natural level of light.

Turns off automatically:

- If no presence is detected and at the end of the time delay set.

- Or if the natural light level is sufficient (regulation activated)

Another detection causes automatic switch-on if there is insufficient light.

 **Walk-through mode:**

- If no presence is detected in the 20 seconds following an initial detection, the product will cut off the load after 3 minutes.

- If another presence is detected in the 3 minutes following initial detection, the device will cut off the load at the end of the set time delay.

 **Manual on/Auto off mode:**

Comes on via a manual switch, automatic switch off:

- Where no presence is detected and at the end of the time delay set.

After switch-off, any new detection within a 30 second period triggers an automatic switch-on. The Restart function must be activated.

After 30 seconds the device is switched on via a manual switch.

Detection system:

Initial detection: The load is switched on as soon as the first detection occurs if the natural light level is below the light level threshold.

Maintain: The load remains active if another presence is detected.

Restart: In manual mode. After switch-off, any new detection within a 30 second period triggers an automatic switch-on.

After 30 seconds the device must be switched on manually.

Alarm: an audible signal is emitted before switch-off. (1 minute before, then 30 seconds, then 10 seconds).

7. SETTINGS (continued)

7.2 Light parameters

Sensor parameter	Default value	Modifiable parameters	Configuration tools	
			0 882 30	0 882 35
Light level threshold	300 lux	20, 100, 300, 500, 1000 lux 0 - 1275 lux	- ✓	✓ -
Advanced mode	Calibration	0 - 99995 lux	✓	-
	Regulation	Activate/Deactivate	✓	-
	Light contribution	Auto - 1275 lux	✓	-

Light level threshold: Value at which the load comes on if the natural light level is less than the setting.

Caution:

The device becomes a motion sensor at 1275 lux.

Advanced mode:

Calibration: The ambient light level measured with a luxmeter must then be transmitted to the sensor (see data sheet Cat. No. 0 882 30)

Regulation: Automatic switch-off of the load 10 minutes after the light level threshold is exceeded with an additional safety threshold (to avoid lights switching off at the wrong moment).

Light contribution: Quantity of additional lux provided by the load being switched on. When the light contribution parameter is set to "Auto" (value 0) on the configuration tool Cat. No. 0 882 30 the sensor automatically calculates the light contribution.

7.3 Modifying the parameters using the configuration tools

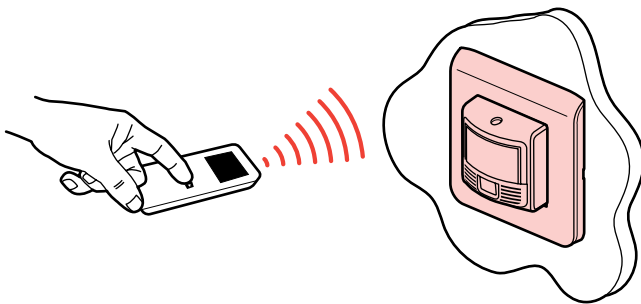

- 0 882 35: Simplified configuration tool
 - 0 882 30: Advanced configuration tool
- When the sensor receives an IR command using the configuration tool it emits a beep acknowledging the modification. For more information about setting parameters, refer to the data sheet for the configuration tool Cat. No. 0 882 30.

Range: 1 m.

- Restore to factory settings:

- 1st press: Short press on LEARN: the LED flashes slowly.
- 2nd press: Press and hold down LEARN for 10 seconds until the LED flashes quickly.

8. PERFORMANCE

Height

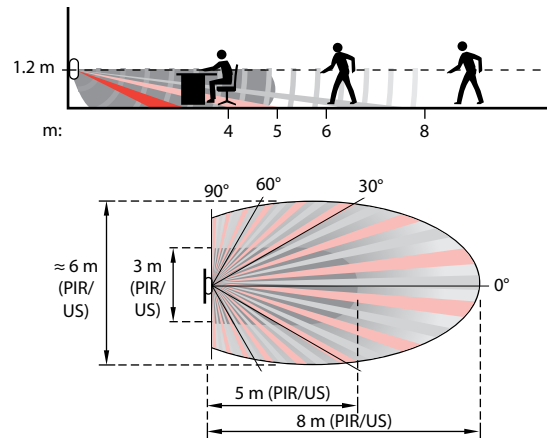

8.1 PIR detection (Walk-through)

Sensitivity	Ø (m)
Low (25%)	7
Medium (50%)	8
High (75%)	10
Very high (100%)	12

8.2 US detection (Walk-through)

Sensitivity	0° (m)	30° (m)	60° (m)	90° (m)
Low (25%)	-	-	-	-
Medium (50%)	6	6	6	2
High (75%)	7	7	6	2
Very high (100%)	8	8	7	3

8.3 PIR + US detection (Presence)

Side test:

Sensitivity	m
Low (25%)	1
Medium (50%)	1
High (75%)	2
Very high (100%)	5

Diagonal then side output test:

Sensitivity	m
Low (25%)	3
Medium (50%)	4
High (75%)	5
Very high (100%)	6

9. CARE

Keep the lens clean.

Clean the surface with a cloth.

Do not use acetone, tar-removing cleaning agents or trichloroethylene.

Resistant to the following products: - Hexane (EN 60669-1)

- Methylated spirit
- Soapy water
- Diluted ammonia
- Bleach diluted to 10%
- Window-cleaning products.

Caution:

Always test before using other special cleaning products.

10. STANDARDS

Directive: CE

Installation standards: NFC 15-100

Product standards: IEC 60669-2-1

Environmental standards:

- European Directive 2002/96/EC:
WEEE (Waste Electrical and Electronic Equipment).
- European Directive 2002/95/EC:
RoHS (Restriction of Hazardous Substances).
- Decrees and/or regulations: ERP (public buildings)
ERT (workplace buildings)
IGH (high-rise buildings)

11. TROUBLESHOOTING

PROBLEM	CAUSES	SOLUTIONS
Lighting stays on when there is no-one present	Sources of interference can cause false tripping, such as: air current, vibrations, radiators	1- Reduce the sensitivity level 2- If the interference continues: using the configuration tool, go into the Detection system parameters, select Maintain and then choose PIR and US 3- If the interference still continues, move the sensor away from sources of interference
Lighting does not switch off during the day when there is an adequate level of natural light	Regulation function not active Light level threshold set too high Light contribution is too high	Activate the regulation function Reduce the light level threshold Check that the sensor is positioned correctly in relation to the window Decrease the power of the luminaires
Lighting switches off when there are people present and the natural light level is not adequate (darkness)	Time delay too short Detection sensitivity too low Light level threshold too low	Increase the time delay 10 to 1 minutes is recommended for work areas Increase the sensitivity Move the sensor closer to the work area Increase the threshold